



## GMP231 Carbon Dioxide Probe for CO<sub>2</sub> Incubators



### Features

- Maximum temperature durability +195 °C (+383 °F)
- Incubator can be heat sterilized with probe in place, saving time and reducing risk of cross-contamination
- Heat durability and excellent long-term stability with next generation CARBOCAP® sensor
- Designed for OEM use in CO<sub>2</sub> incubators – installation options available
- CO<sub>2</sub> sensor measurement optimized for 5 % CO<sub>2</sub>, measurement range up to 20 % CO<sub>2</sub>
- 4-point traceable calibration for CO<sub>2</sub>

Vaisala CARBOCAP® Carbon Dioxide Probe GMP231 withstands high temperature sterilization.

GMP231 is designed to provide incubator manufacturers with accurate and reliable carbon dioxide measurements and sterilization durability at high temperatures. The probe is based on Vaisala's patented CARBOCAP® technology and a new type of infrared (IR) light source. These technologies allow for continuous sterilization temperatures of up to 180 °C (+356 °F), enabling easier and more complete sterilization without the risk of cross-contamination. Maximum temperature durability of +195 °C (+383 °F) provides a comfortable operating margin.

The probe is installed through the incubator wall, ensuring that only the IR sensor and optical components are exposed to the incubation

environment. This allows the incubator to be sterilized with the probe in place, removing the need to decontaminate the probe separately. This saves time and reduces the risk of contamination.

The probe's sensor performance is optimized at 5 %CO<sub>2</sub>, but the sensor measures CO<sub>2</sub> up to 20 % with high accuracy. In addition, GMP231 can measure pressure and temperature for CO<sub>2</sub> measurement compensation purposes, ensuring the product remains stable and accurate in all CO<sub>2</sub> incubation conditions. The sensor is made of highly durable materials to achieve outstanding stability over both time and temperature.

Since water vapor, dust, and most chemicals do not affect measurements, GMP231 module is ideal for CO<sub>2</sub> incubator environments.

### Benefits

- Internal pressure and temperature measurement improves accuracy and stability
- Full temperature and pressure compensations available
- Sensor head heating for condensation prevention

# Technical Data

## Measurement Performance

Measurement range	0 ... 20 %CO <sub>2</sub>
Calibration uncertainty at 5 %CO <sub>2</sub>	±0.1 %CO <sub>2</sub>
Start-up time	< 20 s
Warm-up time for full spec.	< 3 min

### Response Time

T63	< 30 s
T90	< 50 s

### Accuracy at 37 °C, 1013 hPa

Repeatability at:	
0 ... 8 %CO <sub>2</sub>	±0.1 %CO <sub>2</sub>
8 ... 12 %CO <sub>2</sub>	±0.2 %CO <sub>2</sub>
12 ... 20 %CO <sub>2</sub>	±0.4 %CO <sub>2</sub>
Non-linearity at 0 ... 20 %CO <sub>2</sub>	±0.1 %CO <sub>2</sub>

### Temperature Dependence

With compensation at 3 ... 12 %CO <sub>2</sub> , 20 ... 60 °C	±0.1 %CO <sub>2</sub>
Without compensation (typical)	-0.4 % of reading/°C

### Pressure Dependence

With compensation at 3 ... 12 %CO <sub>2</sub> , 700 ... 1100 hPa	±0.015 % of reading/hPa
Without compensation (typical)	+0.15 % of reading/hPa

### Humidity Dependence

With compensation at 0 ... 20 %CO <sub>2</sub> , 0 ... 100 %RH	±0.9 % of reading (at 37 °C)
Without compensation (typical)	+0.05 % of reading/%RH

### O<sub>2</sub> dependence

With compensation at 0 ... 20 %CO <sub>2</sub> , 0 ... 90 %O <sub>2</sub>	±0.6 % of reading
Without compensation (typical)	-0.08 % of reading/%O <sub>2</sub>

### Long-term Stability

0 ... 8 %CO <sub>2</sub>	< ±0.2 %CO <sub>2</sub> /year
8 ... 12 %CO <sub>2</sub>	< ±0.5 %CO <sub>2</sub> /year
12 % ... 20 %CO <sub>2</sub>	< ±1.0 %CO <sub>2</sub> /year

## Mechanical Specifications

Connector	M12/8 pin
Weight	150 g (5.29 oz) without cable
IP rating	IP54 (sensor head) IP20 (electronics housing)

### Materials

Housing	Metal coated plastic ABS+PC
Inner tube	Aluminum
Probe tube	PPSU
Filter	PTFE

### Dimensions

Probe tube max. diameter	30.2 mm (1.19 in)
Probe tube length	118.5 mm (4.67 in)
Sensor filter length	12 mm (0.47 in)

## Operating Environment

Operating temperature for CO <sub>2</sub> measurement	0 ... +70 °C (+32 ... +158 °F)
Max. temperature durability in standby mode (sensor head only)	Max. +195 °C (+383 °F)
Heat sterilization 180 °C durability	At least 120 cycles
Storage temperature	-40 ... +75 °C (-40 ... +167 °F)
Pressure (compensated)	500 ... 1100 hPa
Pressure (operating)	< 1500 hPa
Humidity	0 ... 100 %, non-condensing
Condensation prevention	Sensor head heating when power on
Chemical tolerance	DMSO, IPA (70 %), H <sub>2</sub> O <sub>2</sub> (2000 ppm, non-condensing), ethanol, acetic acid
Electromagnetic compatibility	EN61326-1, Generic Environment

## Inputs and Outputs

Digital outputs	I <sup>2</sup> C 5 V, RS-485 (2-wire with Vaisala industrial protocol)
Analog output	0 ... 20 mA (scalable) max. load 600 Ω
Power consumption	< 1 W (pulsed)
Operating voltage	11 ... 30 VDC 20 ... 30 VDC (with analog output)

## Accessories

M12 Connection Cable 0.9 m with open ends	DRW240977SP
M12 Connection Cable 0.6 m with Milli-Grid connector	ASM210903SP
Silicone plug	DRW240015SP
Attachment bracket	DRW240247SP
PTFE filter	DRW240494SP
USB PC connection cable	221040
MI70 connection cable	221801
Calibration adapter for GMP231	239523

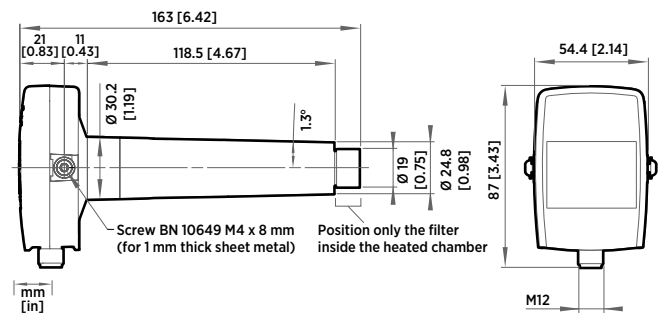

Dimensions



Published by Vaisala | B211312EN-D © Vaisala 2019

All rights reserved. Any logos and/or product names are trademarks of Vaisala or its individual partners. Any reproduction, transfer, distribution or storage of information contained in this document is strictly prohibited. All specifications – technical included – are subject to change without notice.

**VAISALA**

www.vaisala.com